

## CLIENT & WHEELCHAIR DIMENSION INFORMATION

Name: \_\_\_\_\_  
 Address: \_\_\_\_\_  
 \_\_\_\_\_

Vehicle: \_\_\_\_\_  
 Model/Year: \_\_\_\_\_ / \_\_\_\_\_  
 Phone #: \_\_\_\_\_

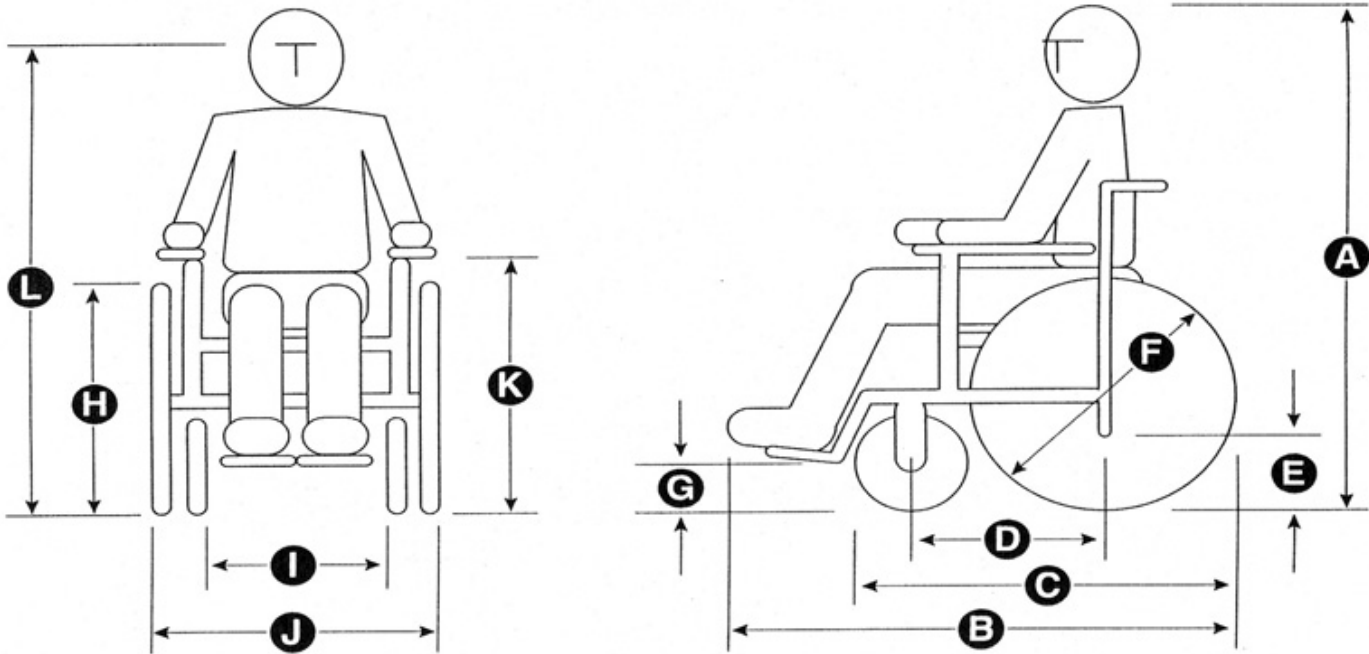

Type of Wheelchair: \_\_\_\_\_  
 Manual  Electric  Wheelchair Supplier; \_\_\_\_\_

### DIMENSIONS

A\* \_\_\_\_\_  
 B\* \_\_\_\_\_  
 C\* \_\_\_\_\_  
 D \_\_\_\_\_  
 E \_\_\_\_\_  
 F \_\_\_\_\_  
 G\* \_\_\_\_\_  
 H \_\_\_\_\_  
 I \_\_\_\_\_  
 J\* \_\_\_\_\_  
 K \_\_\_\_\_  
 L \_\_\_\_\_

\* Critical Dimensions

### SPECIAL NOTES

\_\_\_\_\_  
 \_\_\_\_\_  
 \_\_\_\_\_  
 \_\_\_\_\_  
 \_\_\_\_\_  
 \_\_\_\_\_  
 \_\_\_\_\_  
 \_\_\_\_\_  
 \_\_\_\_\_  
 \_\_\_\_\_